

GRATING ANTISLIP STRIPS & SAFEPLATES



30 years

Advance Anti-Slip Surfaces manufacture a concise range of Class One, ready to install, metal backed antislip Safeplates and Antislip Strips that are specifically designed for mesh grating walkways, ramps, landings and platforms to provide superior traction and a durable non-slip surface.

Antislip Strips come in standard profiles of 50mm in depth (B) and varied width (A), Antislip Safeplates come in standard profiles from 600mm to 1200mm in depth (B) and varied width (A), that are intended to suit most pedestrian access walkways, ramps, landings and platforms.



STANDARD SIZE COMBINATIONS

ANTISLIP STRIPS

Width (A)	+	Depth (B)
580mm		50mm
730mm		50mm
880mm		50mm
1030mm		50mm
1180mm		50mm

ANTISLIP SAFEPLATES

Width (A)	+	Depth (B)
600mm		600mm
600mm		1200mm
750mm		1200mm
900mm		1200mm
1200mm		1200mm

Custom sizes available, Made To Order

PRODUCT FEATURES

- Provides secure footing on wet & oily surfaces
- Robust, durable, reliable
- Available in many colour options
- Pre-Drilled for simple installation
- Australian Standard 4586:2013 compliant
- Backed by Advance Anti-Slip's extensive warranty
- High impact resistance
- Excellent chemical & UV resistance
- Long effective life
- Easy to clean.

HOW TO MEASURE SAFEPLATE

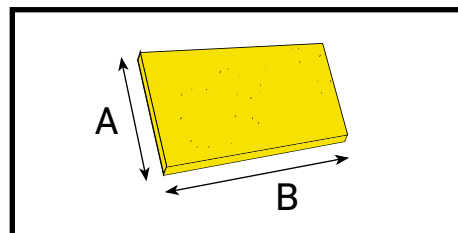

GRADES

Ind = Industrial 24
 HD = Heavy Duty 20
 OS = Offshore 16

COLOURS

SY = Safety Yellow
 BK = Black
 BR = Brown
 GR = Green
 GY = Grey
 BL = Blue
 RD = Red
 WH = White
 Oth = Other

FOUNDATIONS

GL = Galvabond® 1.2mm
 AL1.6 = 5052 Aluminium 1.6mm
 SS1.2 = 316 Stainless Steel 1.2mm

ADVANCE ANTI-SLIP SURFACES Pty. Ltd.

6A Aristoc Road, Glen Waverley 3150, Victoria, Australia

P: +61 3 9560 4488 F: +61 3 9562 0449 E: sales@advanceantislip.com

www.advanceantislip.com

GRATING ANTISLIP STRIPS & SAFEPLATES



ADVANCE
ANTI-SLIP SURFACES P/L

30 years

INSTALLATION GUIDE

Universal Clamp Assembly at regular intervals

Pre-drilled holes come as standard

If additional holes are required, mark the hole positions and drill through from the underside of the foundation.

Make sure there are sufficient holes to anchor the antislip strips or antislip safeplates to the mesh grating structure.



AS 1657 – 2013 Section 3.1.3 Slip Resistance

Walking surfaces, including steps, treads and rungs, shall be slip resistant.

Notes:

1. Guidance for the identification and reduction of slip hazards is given in AS/NZS 3661.2 and HB197.
2. Suitable test methods of slip resistance for pre-existing and new surfaces is given in AS 4586 and AS 4663.

ADVANCE SAFEPLATE OR STRIP

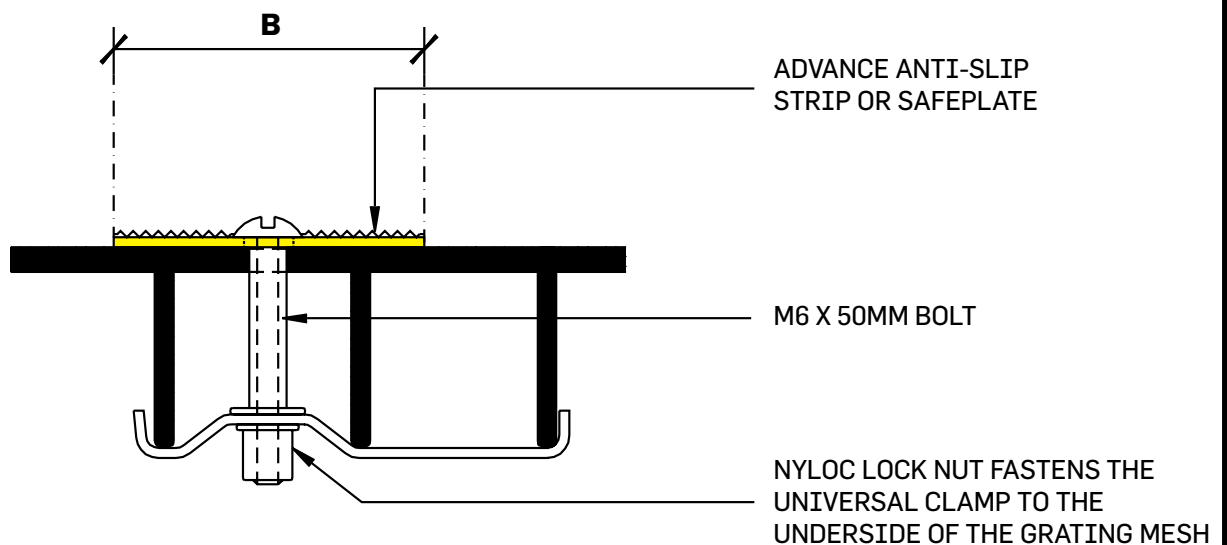

ADVANCE ANTI-SLIP SURFACES Pty. Ltd.

6A Aristoc Road, Glen Waverley 3150, Victoria, Australia

P: +61 3 9560 4488 F: +61 3 9562 0449 E: sales@advanceantislip.com

www.advanceantislip.com